

RB 4600

Commercial & Industrial Regulator

The RB 4600 regulator is designed for use in city gate or district stations where overpressure protection is provided by a combination of an active regulator and an monitor regulator with an upstream slam-shut valve.



Description

The RB 4600 is a pilot-operated regulator with a monitor regulator and a safety shut-off device built into a single compact unit. Its pilot system provides a fast and accurate response to flow rate variation. The monitor pilot system is specially fast to react and to take over in case the active regulator fails to control the outlet pressure. The optional built-in shut-off valve offers protection for overpressure or over-and under-pressure. Its bypass system eases the shut-off valve relatching.

Key Benefits

- » Compact
- » High flow capacity
- » Accurate control
- » Low differential
- » Easy maintenance
- » Rugged construction for durability
- » Travel indicators

Technical Features

Inlet pressure	25 bar
Outlet pressure	5 mbar – 13 bar
Differential pressure	0.5 bar mini
Accuracy	Up to AC1 / up to SG 2.5
Operating temperature	-20°C to +60°C
Acceptable gases	Natural gas, town gas, propane, butane, air, nitrogen or any non-corrosive gas
Safety devices	Optional built-in safety shut-off valve: Over-pressure shut-off (OPSO) and under-pressure shut-off (UPSO)
Options	Noise reduction

Sizes & Connections

Sizes	DN 25, DN 40, DN 50, DN80, DN100
Body lengths	EN 334 face-to-face recommended dimensions
Body rating and Flanges	Steel: DN100 only: PN16, PN25, ANSI150 Steel: DN25, DN50, DN80, DN100: ANSI300 Cast iron: PN16, PN25, ANSI150

Materials

Body	Spheroidal graphite cast iron EN 1563 grade EN-GJS-400-18 Steel EN 10213-3 grade G 20 Mn 5
Head	Pressed steel / UNI EN10025
Internal parts & Pilot	Steel, stainless steel, brass and aluminium
Seals	Nitrile rubber
Diaphragm	Synthetic rubber with fabric reinforcement

Operational Diagram

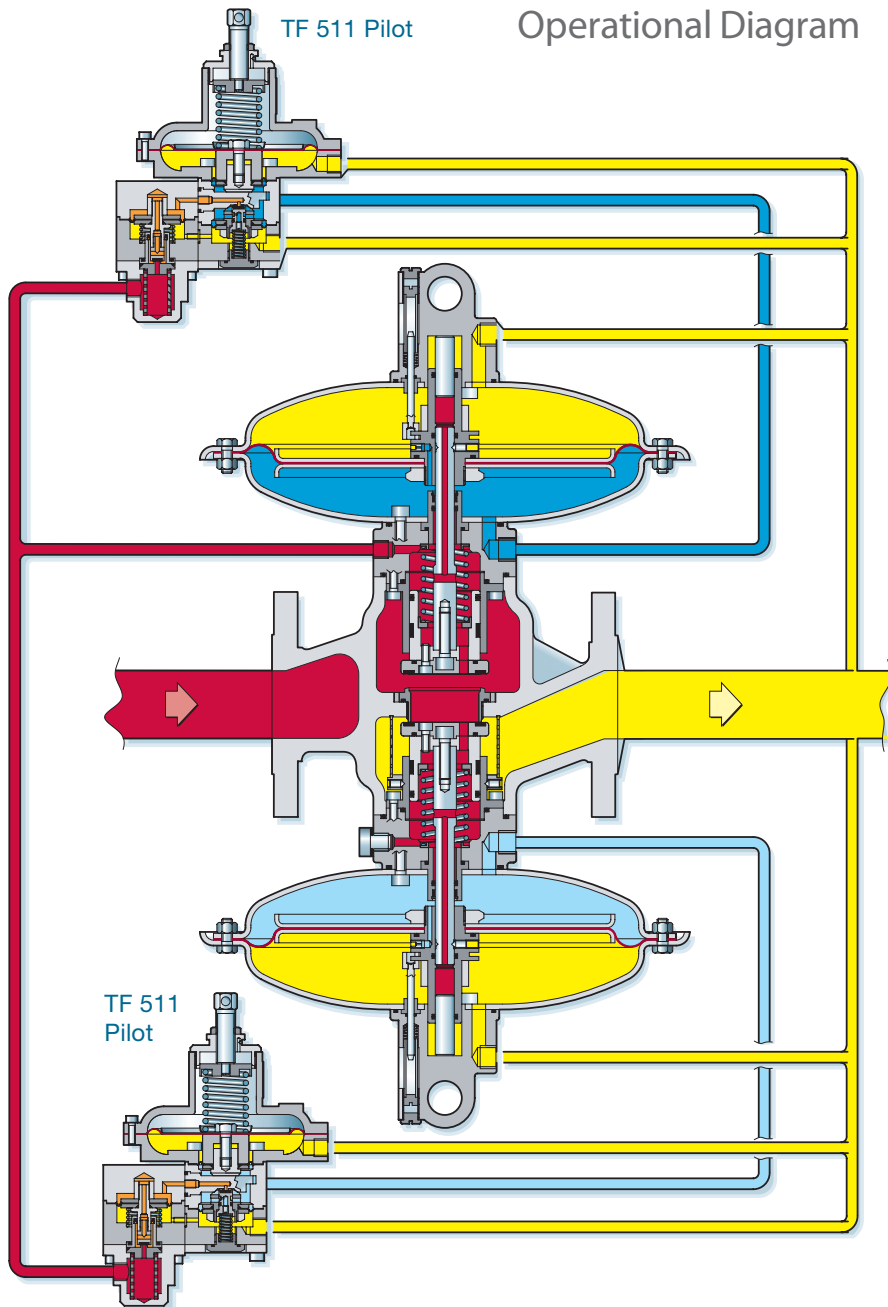

- Inlet Pressure
- Outlet Pressure
- Feeding Pressure
- Motorization Pressure - Monitor
- Motorization Pressure - Active

Accuracy class (AC), lock-up pressure class (SG) and lock-up pressure zone:

- » 10 - 100 mbar: AC 2.5 / SG 5
- » 100 mbar: AC 1 / SG 2.5

The typical lock-up pressure zone is:

$$\frac{Q_{min, Pu}}{Q_{max, Pu}} = \frac{2.5}{100}$$

Type Designation and Options

To specify the version of the RB 4600 series to be ordered, select the options and relevant codes from the table below.

R	B	E	4	6	X	X	DN	X	X	Options
					1					Pilot TF 511
					2					Pilot TF 512
					3					Pilot TF 513
					0					Without safety device
					1					Over-pressure shut-off
					2					Over- and under-pressure shut-off
							25			Orifice (Ø 30 mm)
							40			Orifice (Ø 38 mm)
							50			Orifice (Ø 48 mm)
							80			Orifice (Ø 78 mm)
							100			Orifice (Ø 98 mm)
									S	With integral silencer

Example: Model RBE4711 DN25 S is a regulator with a TF 511 pilot, an over-pressure shut-off and silencer.

Pilot System

The RB 4600 regulator includes 2 pilot operated regulators, each of them being controlled by a pilot system serie TF 500 as follows:

TF 5	1	X	Options
		1	Low pressure: 5 - 280 mbar
		2	Medium pressure: 0.1 - 1 bar
		3	High pressure: 0.25 - 13 bar

Spring characteristics:

d: wire diameter Lo: height
De: external diameter Lt: no. of spires

Standard conditions:

- Absolute pressure of 1.013 bar
- Temperature of 15°C

Outlet Pressure Range

Pilot Type	Spring Code	Spring Characteristic				Spring Range	
		d (mm)	De (mm)	Lo (mm)	Lt	mbar	bar
TF 511	20565125	2.5	35	50	6	5 - 25	
TF 511	20565126	3	35	50	6	20 - 68	
TF 511	20565127	3.5	35	50	6	40 - 140	
TF 511	20565128	4	35	50	6	80 - 280	
TF 512	20565128	4	35	50	6		0.1 - 0.6
TF 512	20565129	4.5	35	50	6		0.2 - 1
TF 513	20565132	3.5	35	60	6.5		0.25 - 1.3
TF 513	20565133	4	35	60	6.5		0.5 - 2.5
TF 513	20565131	5	35	60	6.5		1.5 - 5.5
TF 513	20565134	6	35	60	6.5		4 - 13

The TF 500 series pilot system includes a built-in pre-regulator which is loaded by the outlet pressure to provide the pilot with a feeding pressure 500 mbar above outlet pressure.

The pre-regulator is fitted with a separate filter.

Remote Control

The TF 512-PL series pilot system is designed for applications where the regulator set point must be controlled remotely, such as leak management systems, process control applications, etc. In the TF 512-PL series pilot system, the pilot setting element, which is a spring in conventional pilots, is replaced by an external loading pressure. See separate Technical Information Bulletin

Flow Capacity

Sizing Equation

For a 0.6 specific gravity gas, the wide-open orifice flow (Q) may be calculated using the following equations:

- » Sub-critical flow behaviour: $Q = K_G \sqrt{P_d(P_u - P_d)}$ where $(P_u - P_d) \leq 0.5 P_u$
or $Q = K_G \frac{P_u}{2} \sin \left[K1 \sqrt{\frac{(P_u - P_d)}{P_u}} \right]$ where $(P_u - P_d) \leq 0.5 P_u$
- » Critical flow behaviour: $Q = K_G P_u / 2$ where $(P_u - P_d) > 0.5 P_u$

Flow Coefficient KG

DN	25	40	50	80	100	
K_G	520	1.150	2.050	4.400	7.500	Basic
K_G	490	1.050	1.750	3.700	6.000	With SSV and Silencer
K₁	105	105	105	100	95	

Correction factor for non-natural gas applications:

The flow rates are indicated for a 0.6 specific gravity gas. To determine the volumetric flow rate for gases other than natural gas, multiply or calculate the values in the capacity tables using the sizing equations with a correction factor. The table below lists correction factors for some common gases:

Gas type	Specific gravity	Correction factor
Air	1.00	0.77
Butane	2.01	0.55
Carbon dioxide (dry)	1.52	0.63
Carbon monoxide (dry)	0.97	0.79
Natural gas	0.60	1.00
Nitrogen	0.97	0.79
Propane	1.53	0.63
Propane-Air mix	1.20	0.71

Specific gravity or relative density (air = 1, non-dimensional value)

Use the following formula to calculate the correction factor for gases not listed above. In the formula, d is the specific gravity of the gas.

$$\text{Correction factor} = \sqrt{\frac{0.6}{d}}$$

where:

Q = volumetric flow rate in m³/h at standard conditions
P_u = absolute inlet pressure in bar
P_d = absolute outlet pressure in bar
Sin = angle in degrees

Operational Diagram

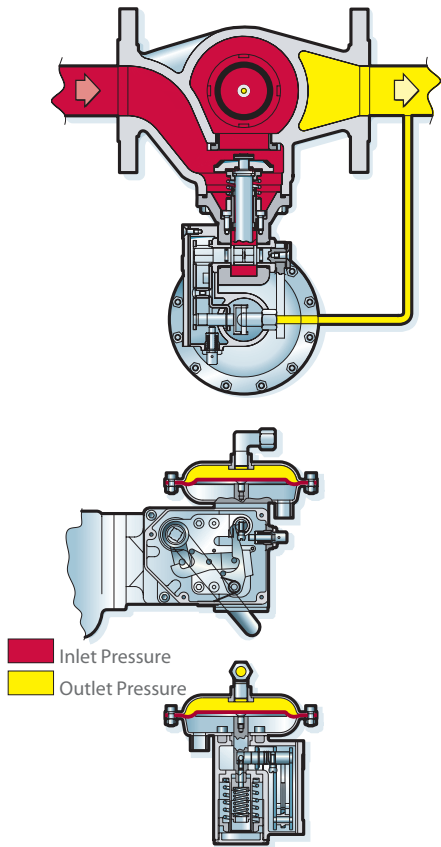

SSV 8600 Safety Shut-off Valve

Accuracy class (AG)

- » Low pressure: AG 10
- » Medium pressure: AG 2.5
- » High pressure: AG 1

Minimum difference between regulator and SSV settings (ΔP_w):

- » 15%, with a minimum difference of 10 mbar for UPSO and 20 mbar for OPSO.

Type Designation and Options

SSV 86	X	X	Versions
	1		∅ 150
	2		∅ 150/TR
	3		∅ 90
	4		∅ 90/TR
		1	OPSO
		2	OPSO + UPSO

The RB 4700 Series regulators can be fitted with the SSV 8600 safety shut-off valve for overpressure (OPSO) or combined under-and-over pressure (UPSO/OPSO) protection.

The SSV trip pressure can easily be adjusted independently of regulator set point.

The following accessories make the SSV 8600 easier to use:

- » Manual shut-off button for emergency closing
- » Easily accessible lever for relatching the valve
- » Built-in bypass for balancing pressure before relatching the safety shut-off valve. Use the relatching lever to operate the bypass.

Remote control accessories (optional):

- » Valve position indicator (inductive detector or Reed switch)
- » Remote triggering by explosion-proof solenoid valve

Spring characteristics:

d: wire diameter Lo: height
De: external diameter Lt: no. of spires

Set Range

Over-Pressure Shut-Off Springs (OPSO)

Spring Code	Spring Characteristic				Colour	Spring Range			
	d (mm)	De (mm)	Lo (mm)	Lt		8611/12 (∅ 150)	8621/22 (∅ 150/TR)	8631/8632 (∅ 90)	8641/8642 (∅ 90/TR)
20565233	2.2	35	60	7	Yellow	28 - 65 mbar	•	•	•
20565234	2.5	35	60	7	Red	45 - 100 mbar	•	•	•
20565330	2.7	35	60	7	White	80 - 140 mbar	•	•	•
20565331	3	35	60	7	Blue	100 - 240 mbar	•	0.60 - 0.90 bar	•
20565332	3.5	35	60	7	Orange	190 - 350 mbar	0.55 - 0.90 bar	0.90 - 1.40 bar	•
20565333	4	35	60	7	Brown	350 - 700 mbar	0.90 - 1.70 bar	1.40 - 2.40 bar	2.30 - 4.10 bar
20565334	4.2	35	60	7	Green	450 - 800 mbar	1.50 - 2.00 bar	2.00 - 3.10 bar	3.10 - 5.00 bar
20565430	4.5	35	60	7	Black	600 - 1000 mbar	1.70 - 2.30 bar	2.50 - 3.90 bar	3.80 - 6.00 bar
20565431	5	35	60	7	Grey	950 - 1300 mbar	2.30 - 3.00 bar	3.90 - 4.60 bar	5.70 - 7.50 bar
20565432	5.5	35	60	7	Yellow	•	•	4.60 - 6.30 bar	7.50 - 10.00 bar
20565134	6	35	60	7	Red	•	•	6.30 - 10.80 bar	10.00 - 15.00 bar

Under-Pressure Shut-Off Springs (UPSO)

Spring Code	Spring Characteristic				Colour	Spring Range			
	d (mm)	De(mm)	Lo (mm)	Lt		8611/12 (∅ 150)	8621/22 (∅ 150/TR)	8631/8632 (∅ 90)	8641/8642 (∅ 90/TR)
20561124	1.2	15	40	10	White	5 - 18 mbar	•	•	•
20561221	1.5	15	40	10	Blue	10 - 55 mbar	•	•	•
20561222	1.7	15	40	10	Orange	30 - 75 mbar	0.11 - 0.29 bar	0.23 - 0.37 bar	0.32 - 0.63 bar
20561223	2	15	40	10	Brown	60 - 150 mbar	0.16 - 0.49 bar	0.26 - 0.66 bar	0.42 - 1.10 bar
20561224	2.5	15	40	10	Green	100 - 250 mbar	0.21 - 0.74 bar	0.32 - 1.00 bar	0.60 - 2.20 bar
20561321	2.8	15	35	7	•	•	•	•	2.20 - 3.30 bar min $\Delta p = 1$ bar

SSV 8500 Safety Shut-off Valve

Accuracy class (AG)

- » Low pressure: AG 10
- » Medium pressure: AG 2.5
- » High pressure: AG 1

Minimum difference between regulator and SSV settings (ΔP_w):

- » Standard: 15% with a minimum difference of 10 mbar for UPSO, 20 mbar for OPSO
- » High pressure: 20% with a minimum difference of 40 mbar for UPSO, 40 mbar for OPSO

The RB 4000 Series regulators (*) can be fitted with the SSV 8500 safety shut-off valve for overpressure (OPSO) or combined under-and-over pressure (UPSO/OPSO) protection.

The SSV trip pressure can easily be adjusted independently of the regulator set point.

The closing plug of the SSV controller is used as pulling tool to relatch the valve. A built-in bypass, for balancing pressure before relatching the safety shut-off valve, is operated by pulling the valve stem.

(*) except for sizes DN 50 x 80 and DN 100.

Operational Diagram

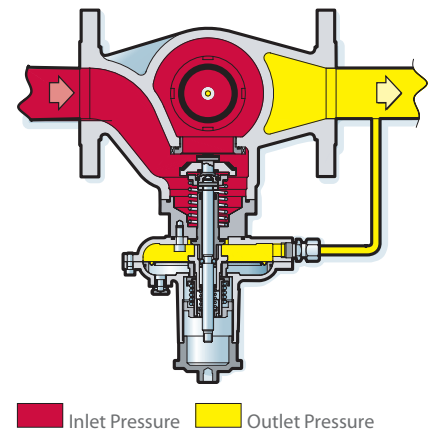

Type Designation and Options

SSV 85	X	X	Versions
	1		Ø 120 or 150
	2		Ø 90
	3		Ø 90/TR
		1	OPSO
		2	OPSO + UPSO

Maximum Inlet Pressure

For higher inlet pressure, the SSV 8500 is fitted with heavier closing spring which gives a positive lock-up even in case of high pressure differential across the valve. The following table indicates the maximum inlet pressure for both options.

DN	25	40	50	80
Standard	6 bar	6 bar	6 bar	6 bar
Heavy duty	16 bar	16 bar	16 bar	6 bar

Spring characteristics:

d: wire diameter Lo: height
De: external diameter Lt: no. of spires

Set Range

Over Pressure Shut-off Springs (OPSO)

Spring Code	Spring Characteristic				Spring Range		
	d (mm)	De (mm)	Lo (mm)	Lt	8511/12 (Ø 150)	8521/22 (Ø 90)	8531/132 (Ø 90 TR)
20565225	2	35	50	6	25 - 49 mbar	0.13 - 0.24 bar	•
20565125	2.5	35	50	6	44 - 120 mbar	0.20 - 0.46 bar	•
20565126	3	35	50	6	95 - 200 mbar	0.42 - 0.90 bar	•
20565127	3.5	35	50	6	200 - 350 mbar	0.83 - 1.84 bar	1.25 - 3.00 bar
20565128	4	35	50	6	•	1.32 - 2.25 bar	2.30 - 4.20 bar
20565129	4.5	35	50	6	•	2.28 - 3.15 bar	3.60 - 5.60 bar

Under Pressure Shut-off Springs (UPSO)

Spring Code	Spring Characteristic				Spring Range		
	d (mm)	De (mm)	Lo (mm)	Lt	8511/12 (Ø 150)	8521/22 (Ø 90)	8531/132 (Ø 90 TR)
20561022	1.2	15	35	7.75	9 - 19 mbar	0.06 - 0.10 bar	•
20560815	1.3	15	35	8	14 - 30 mbar	0.10 - 0.25 bar	0.15 - 0.40 bar
20561023	1.5	15	35	7.75	28 - 60 mbar	0.10 - 0.33 bar	0.30 - 0.60 bar
20561024	1.8	15	35	7.5	60 - 100 mbar	0.30 - 0.70 bar	0.58 - 1.25 bar
20561121	2	15	35	7.25	•	0.60 - 1.10 bar	1.20 - 1.70 bar
20561122	2.5	15	35	7.25	•	•	1.08 - 2.50 bar

Regulator - Overall Dimensions (mm)

DN	Actuator	A*	B	C	D	Weight (kg)
25		184	630	280	360	50
40		222	660	300	360	58
50		254	690	315	360	59
80	with TF 511	298	825	370	480	115
	with TF 512 or TF 513	-	-	-	360	-
100		352	860	395	480	130

*ANSI 300 on request

Vent and Sensing Lines

- » Pilot sensing line: Rp 1/4 with compression fitting for 10 mm pipe
- » Regulator process line: Rp 3/8 with compression fitting for 10 mm pipe

Safety Shut-off Valve - Overall Dimensions (mm)

SSV 8600

DN	Actuator Ø 150		Actuator Ø 90		Additional weight (kg)
	E	F	E	F	
25	290	150	260	90	4
40	305	150	275	90	5
50	310	150	280	90	7
80	375	150	345	90	9

Vent and Sensing Lines

- » SSV sensing line: Rp 1/4 with compression fitting for 10 mm pipe
- » SSV vent line: Rp 1/4

SSV 8500

DN	E	Additional weight (kg)
25	183	2
40	260	3
50	268	5
80	318	5

Vent and Sensing Lines

- » SSV sensing line: Rp 1/4 with compression fitting for 10 mm pipe
- » SSV vent line: Rp 1/8

Information to be specified when ordering:

- » Regulator type code
- » SSV type
- » Minimum and maximum inlet pressures
- » Outlet pressure range setting
- » Outlet pressure setting
- » Connection type
- » Options
 - » OPSO setting*
 - » UPSO setting*

*(if requested)

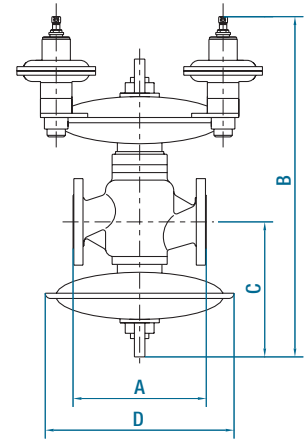

Regulator RB 4600 without SSV

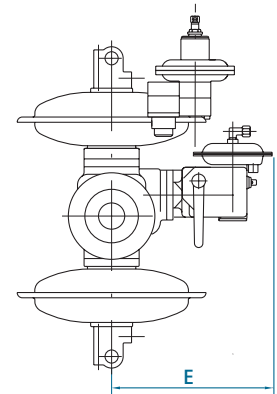
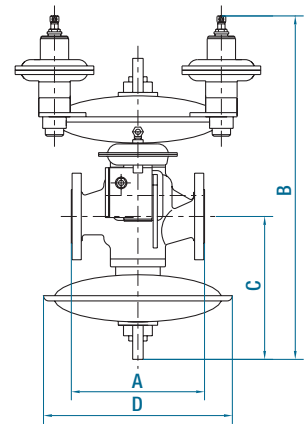

Regulator RB 4600 with SSV 8600

Dresser Utility Solutions GmbH

Hardeckstr. 2

76185 Karlsruhe

T: +49 (0)721 / 5981 - 100

F: +49 (0)721 / 5981 - 282

© 2022 Natural Gas Solutions North America, LLC – All rights reserved. Dresser Utility Solutions reserves the right to make changes in specifications and features shown herein, or discontinue the product described at any time without notice or obligation. Contact your Dresser Utility Solutions representative for the most current information. The Dresser Logo and all Trademarks containing the term "Dresser" are the property of Dresser, LLC, a subsidiary of Baker Hughes.

DRESSER
UTILITY SOLUTIONS
www.dresserutility.com